

BRISTAN

Installation Instructions & User Guide

Please leave these instructions with the end user

Product Code: CRU 3TH BAS Range (D2)

Specification

Dynamic Water Pressure

Min: 0.5 bar Max: 5.0 bar



Maximum Static Pressure: 10.0 bar

Inlet Water Temperature

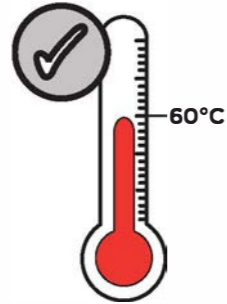

Maximum Hot: 60°C

Inlet Connections

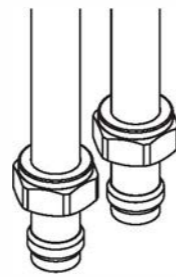

15mm Compression

Outlet



M18.5 5lpm
Coin-Slot Aerator

Pack Contents

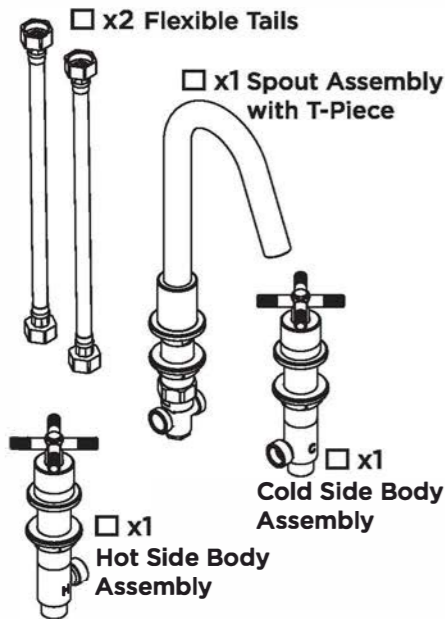

Operation

Hot



Cold

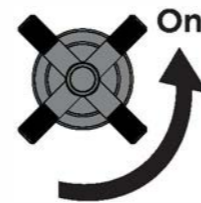

Spout

Tools Required



Prior to Installation

All products manufactured and supplied by Bristan are safe to use provided that they are installed, operated and receive regular maintenance in accordance with these instructions.

This product needs to be installed in accordance with, and meet the requirements of The Water Supply (Water Fittings) Regulations (Northern Ireland) 2009 and The Water Supply (Water Fittings) (Scotland) Byelaws 2014.

For full Installation Requirements & Notes (IRN) please visit www.wrasapprovals.co.uk/approvals-directory

Isolation valves must be fitted to the inlet water supplies to ensure ease of future maintenance.

Before installing this product the water supply must be thoroughly flushed in order to remove any swarf, solder etc. Full access must be made available for future maintenance/servicing purposes.

This product must not be modified in any way as this will invalidate the guarantee.

Spare Parts



To replace any spare parts for your tap, scan the QR Code or visit www.bristan.com and search for your product.

Installation

1

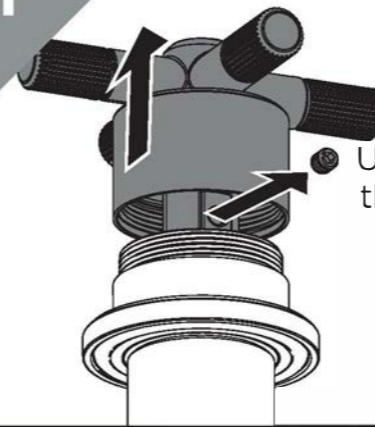

Unscrew and lift the shroud to reveal the grub screw.

Unscrew the grub screw then remove the handle and shrouds.



2

Remove the shrouds, plinths, and washers from the side bodies.

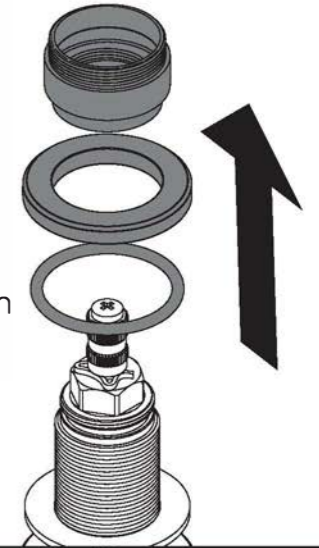

3

Feed the side bodies from underneath with the hot (H) through the left hole and the cold (C) through the right.

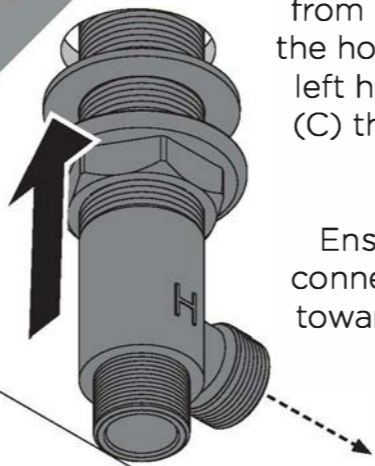

Ensure the angled connectors are facing towards one another.

Re-attach the shrouds, plinths and washers from above the basin.

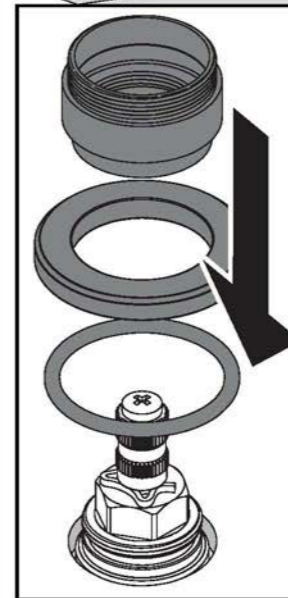

4

Secure the side bodies using the backnuts and washers

Rubber Washer
Backnut



5

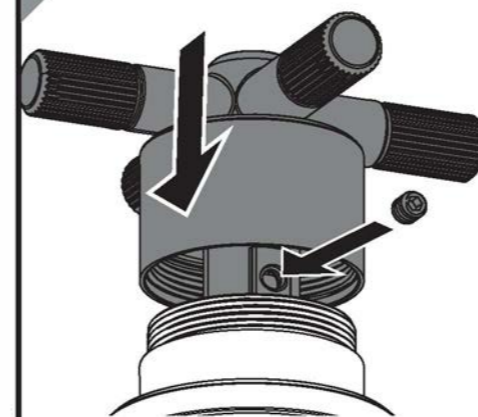

Replace the side body handles to secure in place.

6



Unscrew the T-Piece and washers from the spout thread.

7

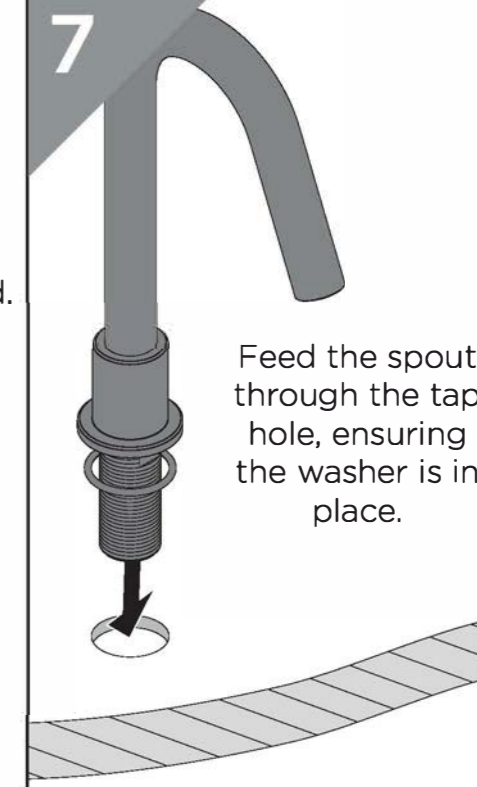

Feed the spout through the tap hole, ensuring the washer is in place.

7 Secure the spout using the backnut and washers.
Fit the T-Piece onto the spout thread and tighten the nut the secure.

8 Connect the T-Piece to the side bodies by hand using the flexible tails.
Connect the hot and cold water supplies to the side body inlets.

Ensure flexible tails are positioned correctly.

9 Your tap is now ready for use.

IMPORTANT
Turn on water supply for a few minutes and check all joints and connections for any leaks.

Valve Replacement

1 Unscrew and lift the shroud to reveal the grub screw.
Remove the grub screw, then the handle and shroud.

2 Remove the screw and spline adaptor.

3 Use a socket spanner to remove the valve.
For replacement valves, see **SPARE PARTS**.

4 Reverse steps to replace the valves and handles.

Outlet Cleaning

1 Insert a coin into the slot in the outlet and twist gently to remove.
(Reverse to replace)

2 Check all loose parts for damage and then soak using a suitable solution to de-scale.

Troubleshooting

Symptom	Cause	Remedy
Low Flow	Partially closed isolation valve.	Open isolation valve.
	Airlock or partial blockage in the supply pipework.	Flush through pipework to ensure removal of debris and any airlocks.
	Partial blockage in the outlet	Remove to Clean and soak in suitable solution.
No hot water or cycling hot and cold	Instantaneous water heater cycles on and off as flow rate or pressure is too low.	Increase water flow rate or pressure through system.
No Flow	Closed isolation valve.	Open isolation valve.
	Mains water supply turned off.	Turn on mains water supply.
Temperatures not corresponding with taps	Inlet pipes have been connected incorrectly	Swap the inlet tails around.

General Cleaning

Bristan products are made from premium materials, with hand polished, electroplated, PVD or EPD finishes.

Your taps or shower should be regularly cleaned with warm water, a mild pH-neutral liquid soap, and polished with a soft cloth. Any residues from soap, toothpaste, shampoos and shower gels can cause blemishes if not rinsed off straight after use.

Household bleaches and cleaners contain harsh chemicals and may damage the surface finish. Avoid using abrasive cloths, scouring pads, scrub sponges, steel wool or anything similar.

Contact Us



Part of BRISTAN GROUP

Bristan Group Ltd.
A Masco Company

UK: Bristan Group,
Pooley Hall Drive,
Birch Coppice Business Park,
Dordon, Tamworth
B78 1SG.

EU: Masco Europe S.à.r.l.
14 Rue Strachen
6933 Mensdorf
Luxembourg

Email Us: enquire@bristan.com
Website: www.bristan.com
Call Us: +44330 026 6273

Our Guarantee

At Bristan, we want to make things as easy as possible for our customers. That's why we offer solid guarantees on all our products, effective from the date of purchase, to give you peace of mind.
Your guarantee starts from the purchase of your product, but you can still benefit from registering it for easier identification in the unlikely event of a manufacturing fault, please visit www.bristan.com/register
For any other queries, please call Customer Service on 0330 026 6273 where our expert team of advisors will be able to offer you any help and advice.
For full guarantee terms and conditions visit www.bristan.com/service-centre/guarantees

